

HEAD TUBE(頭管)

- 1-1/8" (28.6mm) 無牙式前叉立管
(1.5" 車架轉1-1/8" 前叉)
- 鋁合金(6061)上塞
- 鋁合金(6061或7075)上下碗
- 鋁合金(7075或鉻鉬鋼)下塞
- 加大型斜接觸角度密封軸承

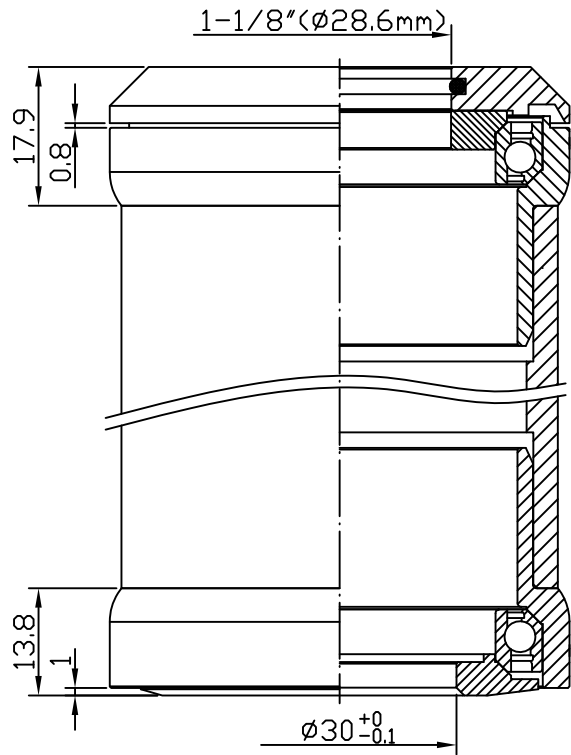

堆積高度(STACK HEIGHT)=31.7±1mm

NO.	零件名稱 PART NAME	材質 MATERIAL	圖號 DRAWING NO.	台量 Q'TY	尺寸 DIM. DESCRIPTION
1	O形圈 O-RING	橡膠 NBR	120-8	1	ID28.5xφ2
2	鋁上塞 TOP COVER	鋁合金 6061/T6	153-3	1	1-1/8"
3	鋁斜管 COMPRESSION RING	鋁合金 6061/T6	153-2	1	1-1/8"
4	密封式軸承 SUPER OVERSISE AC SEALED BEARING	軸承鋼 SUJ2	NHB-15	2	OD52x45° x45°
5	上碗 UPPER CUP	鋁合金 6061/T6	151-4	1	φ49.7±0.15
6	下碗 LOWER CUP	鋁合金 6061/T6	151-5	1	φ49.7±0.15
7	鋁下塞 CROWN RACE	鋁合金 7075/T6	153-6 (153S-6)	1	φ30±0.1

- For 1-1/8" threadless steerer
(1.5" reduced to 1-1/8")
- 6061/T6 top cover with seal
- 6061/T6 cnc machined cups
(7075/T6 cups is optional)
- 7075/T6 cnc machined crown race
(cr-mo steel crown race is optional)
- Super oversize angular contact
sealed bearings

單位 UNIT	mm	比例 SCALE	1:1	日期 DRAWING DATE	2001.01.05	角法 VIEW	
型號 ITEM NO.	NECO 153BW						版次(REV):A
品名 PART NAME	153BW 組立圖(Assembly drawing)						
規格 DIMENSION	1.5" x49.7x30						
圖號 PART NO.	153BW-組立圖-A						

NECO®

誌慶工業股份有限公司